

Global business profile

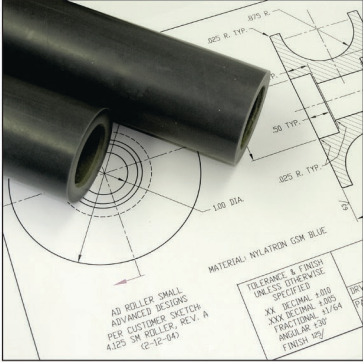

Global leader in engineering plastics for machining.

Distributed by:  **Polymer**shapes****



QUADRANT

You inspire ... we materialize®



YOU INSPIRE:

Our best successes come from close working relationships with our customers – but not just on solving application problems with our materials’ properties. The more we understand about what’s important to your company, what it takes to compete, what determines your success and value with your customers, the better we can apply the right services and product technology for machined components for your equipment.

Let’s work together on your ideas and success factors, like these, where our materials’ can help you better compete in your industry.

EFFICIENCY LOW SYSTEM COST PRODUCT LIFE RELIABILITY YIELD
CONSISTENCY OUTPUT COMPONENT COST COMPETITIVENESS
GLOBAL SOURCING PRODUCTIVITY MARKETING ADVANTAGE
LOW MAINTENANCE LESS DOWNTIME REGULATORY COMPLIANCE



WE MATERIALIZE:

Challenge us with your application requirements. Tell us also what it takes for you to compete and deliver value in your industry. That gives us the opportunity to work with your engineers to provide the best combination of technical support, material and finished part performance for your equipment – within your overall cost targets.

Consider how these benefits of Quadrant materials’ can improve your application reliability, equipment efficiency and bottom line.

LONG WEAR LIFE LOW INTERNAL STRESSES
PREDICTABLE DIMENSIONS STATIC MANAGEMENT
IONIC PURITY STAIN RESISTANCE LIGHTER WEIGHT
SELF-LUBRICATING STRENGTH AT HIGH TEMPERATURE
AGENCY CERTIFICATIONS SEALING INTEGRITY
CHEMICAL AND HYDROLYSIS RESISTANCE

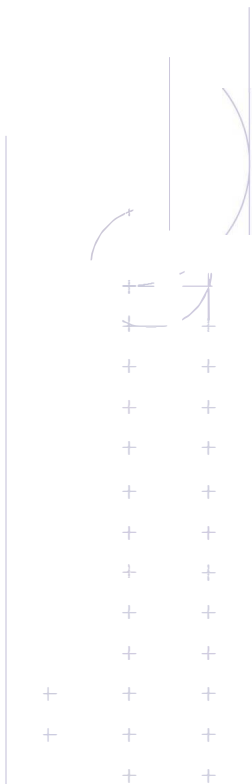



You inspire...we materialize



Quadrant history: The first plastic materials for machining.

Quadrant today: Now the broadest range of materials for the most cost effective choices.



Quadrant tomorrow: New products for new needs, from the industry's only global product and application development team.



For over 60 years, the companies that formed Quadrant have been developing new materials to meet changing demands of our customers around the world. The innovative, collaborative spirit between our people and our customers has shaped our success and led to the industry's broadest range of engineering plastics for machining. Our investment in innovation will only increase in the years ahead, to support your requirements for higher levels of performance, productivity and value.



Quadrant Engineering Plastic Products - Global Scope



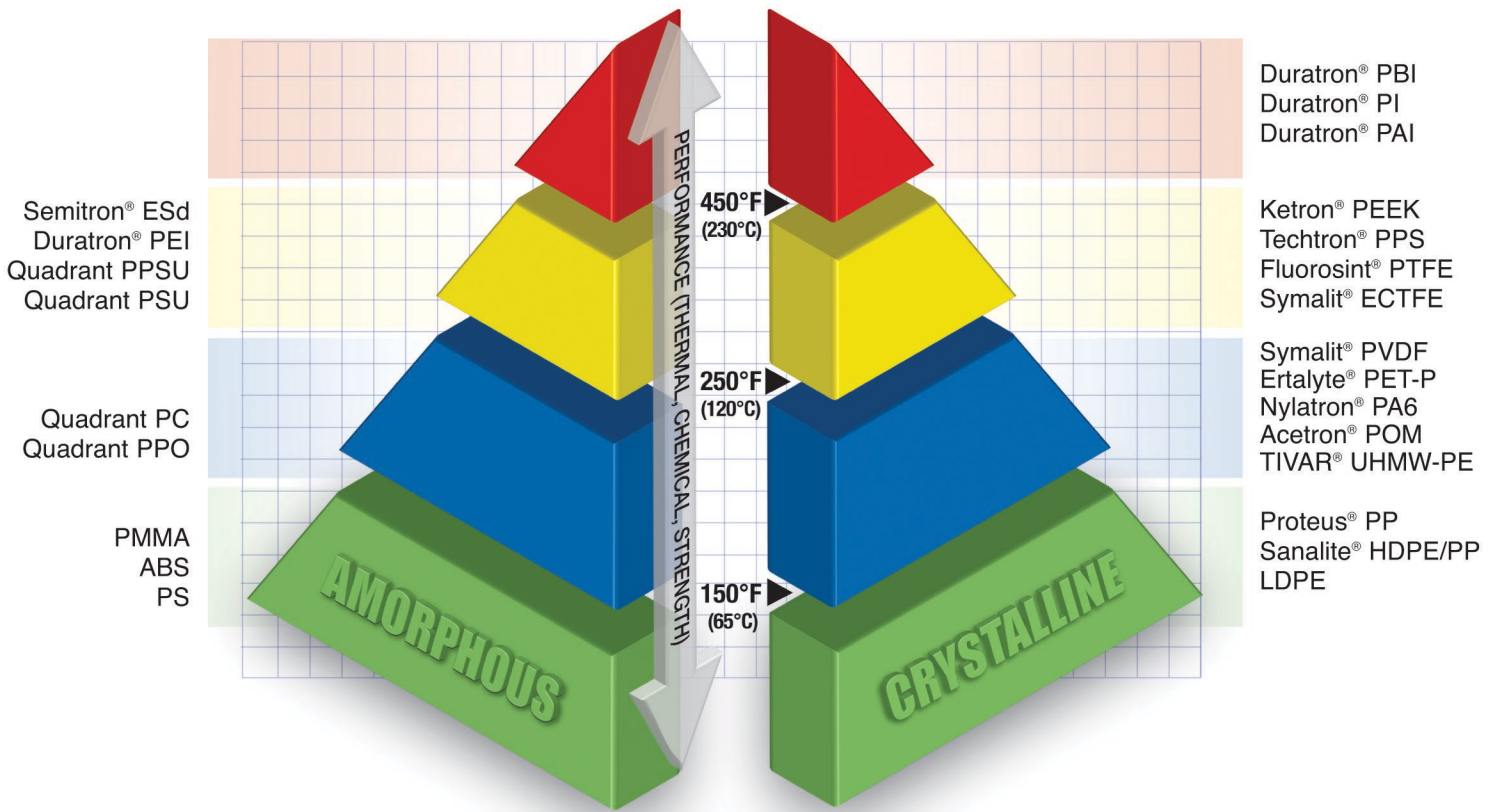

Applications in Major Industries



Construction & Heavy Equipment

Challenge: Improve time between replacement of wear surfaces, reduce or eliminate costly lubrication systems.

Wear pads used in heavy machinery must bear significant loads and minimal chatter with as little costly maintenance and lubrication as possible. Basic nylon materials provided quieter, lighter, more trouble-free service but needed regular replacement.

Solution: Solid lubricant filled Nylatron® 703XL offers "stick-slip" free performance and significant improvement in wear life.

New Technology: Quadrant's unique RIM casting technology provides a cost effective and innovative option for the addition of new features like "cast in" wear indicators and inserts. Innovative materials delivered using innovative new processes.



Industrial & Process Equipment

Challenge: Reduce maintenance, eliminate lubrication systems and improve toughness in industrial equipment.

Trailers that deliver new automobiles to dealerships carry significant loads, endure hostile environments and still need to deliver their cargo without a scratch. This drive mechanism that raises/lowers the expensive cargo needed costly and frequent lubrication and regular repair.

Solution: Easily machined parts made from tough, internally lubricated Nylatron® NSM.

New Technology:

Nylatron® 703XL excels in critical applications with the added benefit of "stick-slip" free performance, eliminating chatter and the subsequent loss of precise control.



Food Processing & Packaging Equipment

Challenge: Eliminate costly maintenance downtime caused by wear prone mixing paddles.

Metal paddles used to stir the abrasive ingredients in commercial candy production required frequent replacement. The aggressive cleaning agents also contributed to galling, corrosion and premature failure.

Solution: TIVAR® 1000 eliminated the abrasion problem and easily withstands the harsh chemicals used for cleaning.

New Technology: New TIVAR® H.O.T. can outlast virgin UHMW-PE by up to 10 times in elevated temperature applications. Its unique combination of abrasion and chemical resistance and improved wear life at higher temperatures makes it ideal for many food equipment applications.





Technical support from concept through production.

Application and production support when and where you need it. Quadrant's technical support team works with engineers and machinists from material selection through machining, for optimum performance, productivity and cost.

Quadrant locations around the world offer an experienced technical team and the most comprehensive testing laboratories in the industry. You can count on reliable support at every phase of your project:

- Evaluation of performance needs and application environment
- Material selection – including selection software
- Material certifications
- Regulatory agency compliance
- Set-up and production recommendations from experienced machinists
- A wide range of material selection, design and fabrication guides and tools – all available on the Quadrant Engineering Plastic Products website, www.quadrantplastics.com

Quality systems that ensure consistency.

From full lot traceability to ISO certifications, Quadrant meets your requirements for consistent quality, performance and machinability. As the first to line mark shapes materials,

Quadrant set the standard for traceability on our products right back to the resin lot and production shift. We have also kept pace with industry standards and quality systems to comply with the needs of the industries that your company also serves. It is the inspiration behind our drive to provide the best levels of support for our materials in your applications. Count on Quadrant.



Chemical Processing & Fluid Handling Equipment

Challenge: Higher output, minimized damage and downtime in compressors.

In turbo-compressor equipment, a small increase in efficiency can deliver a major competitive advantage in output. Also during equipment upsets, internal metal parts can cause serious component damage that requires very costly repairs and downtime.

Solution: Replace aluminum in labyrinth seals with Duratron® PAI. This dimensionally stable, temperature resistant material yields major improvements in efficiency and output. And unlike metal, its ductility also prevents significant damage to other internal components should equipment upsets occur.

New Technology: A higher heat resistant Duratron® PAI extends temperature limits; new Fluorosint® HPV allows use in chlorine service.

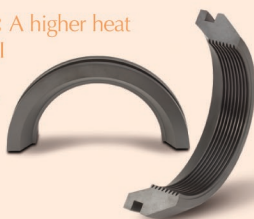

Medical, Life Science & Diagnostic Equipment

Challenge: Provide high strength, high temperature seals that can withstand repeated sterilization—and meet tough compliance standards.

PTFE seals in an industry-leading piece of medical diagnostic equipment were unable to endure high shear forces, remain dimensionally stable and provide a tight seal. Repeated sterilization of the microfluidizer unit and the broad range of temperatures observed during its operation made choosing the ideal material a challenge.

Solution: The PTFE seals were replaced by more stable TIVAR® H.O.T. seals. This innovative manufacturer asked us to push the limits and has already jumped to the next challenge.

New Technology: More stable than TIVAR H.O.T., Fluorosint® 207 can better withstand elevated temperatures and has added strength to handle the high shear forces needed in the application.



Semiconductor & Electronics Manufacturing Equipment

Challenge: Improve productivity; minimize downtime costs in wafer production.

Semiconductor equipment builders continually push the materials technology envelope in highly aggressive chemical and temperature environments to improve silicon wafer output and reduce production costs.

Solution: Techtron® PPS retainer rings for silicon wafer polishing. Quadrant developed a unique material that has become today's standard. Techtron® PPS outperforms traditional materials with its longer wear life for higher productivity and less downtime in the production of wafers.

New Technology: New Semitron® CMP LL5 and XL20 extend the life of retaining rings from 5 to 20 times over current materials.

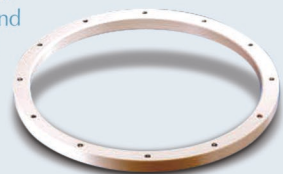



Learn more online at
www.quadrantplastics.com

Quadrant has extensive product and machining resources available online. Our website is a portal to a wealth of technical data and the easiest way to engage our application specialists. Our team stands ready to help offer solutions to your toughest problems.

Distributed by:

 **Polymershapes**

Call: 1 (866) 437-7427
Email: info@polymershapes.com
www.polymershapes.com

Quadrant Engineering Plastic Products Worldwide

EUROPE

Quadrant EPP AG
Hardstrasse 5
CH-5600 Lenzburg
Tel +41 (0) 62 8858259
Fax +41 (0) 62 8858401
e-mail: info@qplas.com

NORTH AMERICA

2120 Fairmont Avenue
PO Box 14235 - Reading, PA 19612-4235
Tel 800 366 0300 / +1 610 320 6600
Fax 800 366 0301 / +1 610 320 6868
e-mail: americas.epp@qplas.com

ASIA-PACIFIC

60 Ha Mei San Tsuen, Ping Shan
YUEN LONG,
N.T. Hong Kong
Tel +852 (0) 24702683
Fax +852 (0) 24789966
e-mail: asia.epp@qplas.com

**BELGIUM • FRANCE • GERMANY • HONG KONG • HUNGARY • INDIA • ITALY • JAPAN • KOREA • MEXICO • POLAND
SOUTH AFRICA • SWITZERLAND • THE NETHERLANDS • UNITED KINGDOM • UNITED STATES OF AMERICA**

All statements, technical information and recommendations contained in this publication are presented in good faith, based upon tests believed to be reliable and practical field experience. The reader is cautioned, however, that Quadrant Engineering Plastic Products does not guarantee the accuracy or completeness of this information and it is the customer's responsibility to determine the suitability of Quadrant's products in any given application.

Acetron, Duraspin, Duratron, Erta, Ertacetal, Ertalene, Ertalon, Ertalyte, Extreme Materials, Fluorosint, Ketron, MC, Monocast, Novatron, Nylatrack, Nylatron, Polypenco, Proteus, Sanalite, Semitron, Symalit, Techtron, TIVAR, Ultrawear and Vibratuf are registered trademarks of the Quadrant group of companies.

*Classix is a registered trademark of Invibio Ltd. Corp.

*Rulon is a registered trademark of Saint Gobain Performance Plastics

*Torton is a registered trademark of Solvay Advanced Polymers

*Vespel is a registered trademark of E.I. DuPont